

WAGNER

Earlex® **5700**

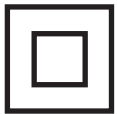
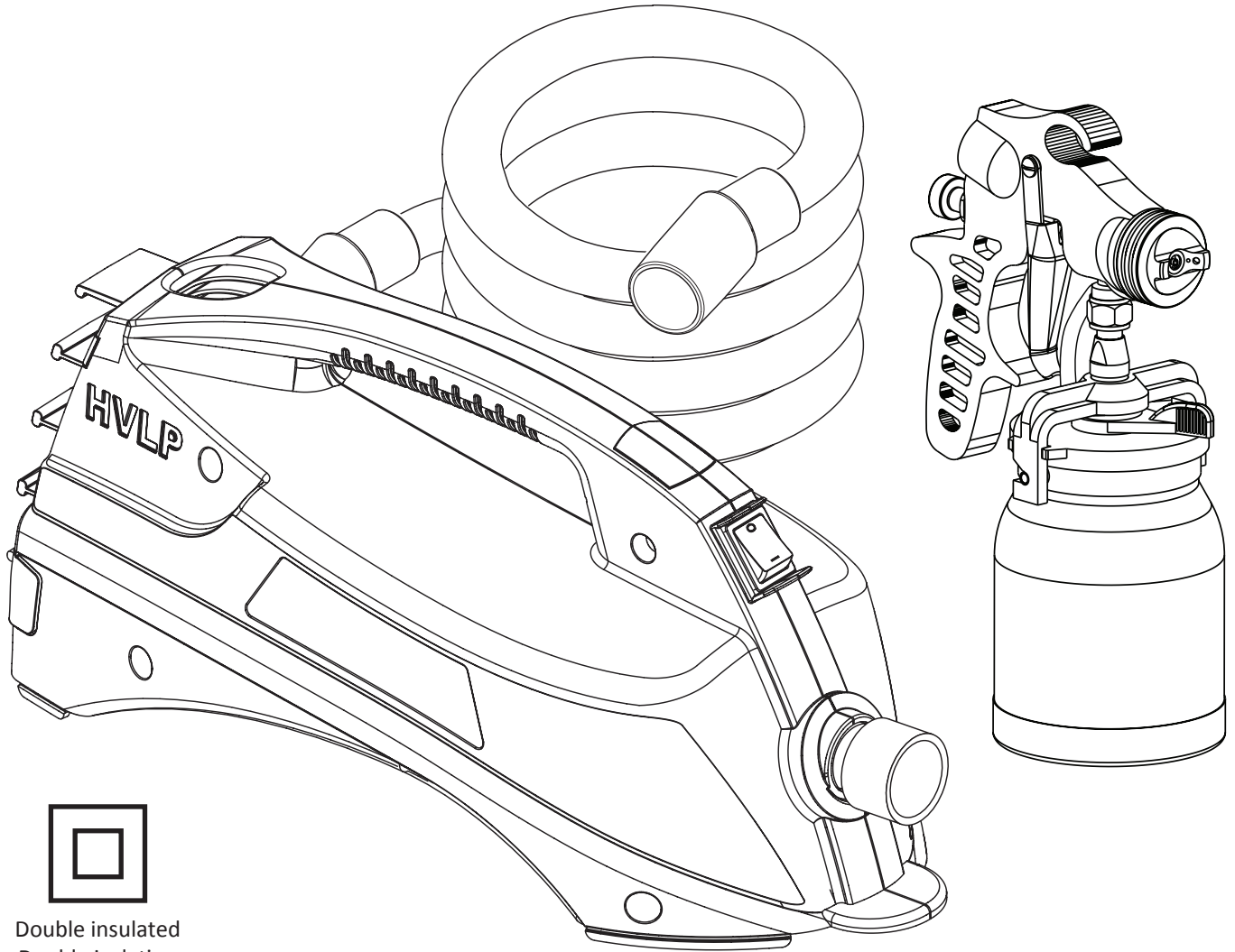

Double insulated
Double isolation
Aislamiento doble

OWNER'S MANUAL • MANUEL DE L'UTILISATEUR • MANUAL DE USARIO

READ THIS MANUAL FOR COMPLETE INSTRUCTIONS •

LIRE CE MANUEL POUR OBTENIR DES DIRECTIVES COMPLÈTES •

LEA ESTE MANUAL PARA OBTENER LAS INSTRUCCIONES COMPLETAS

PLEASE READ AND SAVE THIS INSTRUCTION MANUAL ENGLISH • FRANÇAIS • ESPAÑOL

IMPORTANT SAFETY INFORMATION

TABLE OF CONTENTS

IMPORTANT SAFETY INFORMATION	2-3
CONTROLS AND FUNCTIONS.....	4-5
MATERIAL PREPARATION	6
ASSEMBLY	7
SPRAYER CONTROLS.....	8
PROPER SPRAYING TECHNIQUE.....	9
CLEANUP	10-11
MAINTENANCE	12
TROUBLESHOOTING.....	13
PARTS LIST.....	38-39
LIMITED WARRANTY	40

EXPLANATION OF SYMBOLS

Read all safety information before operating the equipment. Save these instructions.

To reduce the risks of fire or explosion, electrical shock and the injury to persons, read and understand all instructions included in this manual. Be familiar with the controls and proper usage of the equipment.



→ This symbol indicates a potential hazard that may cause serious injury or loss of life. Important safety information will follow.



→ This symbol indicates a potential hazard to you or to the equipment. Important information that tells how to prevent damage to the equipment or how to avoid causes of minor injuries will follow.



→ Danger of fire from solvent and paint fumes



→ Danger of explosion from solvent, paint fumes and incompatible materials



→ Electric shock hazard



→ Notes give important information which should be given special attention.

SERVICING OF A DOUBLE-INSULATED PRODUCT

In a double-insulated product, two systems of insulation are provided instead of grounding. No grounding means is provided on a double-insulated product, nor should a means for grounding be added to the product. Servicing of a double-insulated product requires extreme care and knowledge of the system, and should be done only by qualified service personnel. Replacement parts for a double-insulated product must be identical to those parts in the product.

IMPORTANT ELECTRICAL INFORMATION

Use only an extension cord that will accept the plug on the product. Make sure your extension cord is in good condition. When using an extension cord, be sure to use one heavy enough to carry the current your product will draw. An undersized cord will cause a drop in line voltage resulting in loss of power and overheating. A 12 or 14 AWG minimum cord is recommended. Outdoor extension cords should be used with outdoor use products and are surface marked with suffix letter "W" and with a tag stating "Suitable for Use Outdoors". The connection of the cord should be kept dry and off the ground.

This appliance has a polarized plug (one blade is wider than the other). To reduce the risk of electric shock, this plug is intended to fit in a polarized outlet only one way. If the plug does not fit fully in the outlet, reverse the plug. If it still does not fit, contact a qualified electrician. Do not modify the plug in any way. This unit contains no serviceable electrical parts. Do not attempt to service yourself.



Household use only. Intended for indoor/ outdoor use ONLY with materials having flashpoint above 100°F (38°C).

IMPORTANT SAFETY INFORMATION

SAFETY HAZARDS

	HAZARD: EXPLOSION OR FIRE Flammable vapors, such as solvent and paint vapors, in work area can ignite or explode.
-----------------------------------------------------------------------------------	-----------------------------------------------------------------------------------------------------------------------------

PREVENTION:

- Do not spray flammable or combustible materials near an open flame, pilot lights or sources of ignition such as hot objects, cigarettes, motors, electrical equipment and electrical appliances. Avoid creating sparks from connecting and disconnecting power cords.
- For use with only water-based or mineral spirit-type materials with a minimum flash point of 100°F (38°C) — Do not spray or clean with liquids having a flash point of less than 100°F (38°C). Flash point is the temperature at which a fluid can produce enough vapor to ignite.
- Verify that all containers and collection systems are grounded to prevent static discharge.
- Keep spray area well ventilated. Keep a good supply of fresh air moving through the area to keep the air within the spray area free from accumulation of flammable vapors. Keep turbine assembly in well ventilated area. Do not spray turbine assembly.
- Do not smoke in the spray area.
- Do not operate light switches, engines, or similar spark producing products in the spray area.
- Keep area clean and free of paint or solvent containers, rags, and other flammable materials.
- Know the contents of the paint and solvents being sprayed. Read all material Safety Data Sheets (SDS) and container labels provided with the paints and solvents. Follow the paint and solvent manufacture's safety instructions.
- Fire extinguisher equipment shall be present and working.

	HAZARD: ELECTRIC SHOCK This product can cause injury due to electric shock.
-----------------------------------------------------------------------------------	---------------------------------------------------------------------------------------

PREVENTION:

- Never submerge electrical parts.
- Never expose the equipment to rain. Store indoors.
- Keep electrical cord plug and spray gun trigger free from paint and other liquids. Never hold the cord at plug connections to support the cord. Failure to observe may result in an electrical shock.

	HAZARD: GENERAL This product can cause severe injury or property damage.
-----------------------------------------------------------------------------------	------------------------------------------------------------------------------------

PREVENTION:

- Always wear appropriate gloves, eye protection, clothing and a respirator or mask when painting. Hazardous vapors – Paints, solvents, insecticides, and other materials can be harmful if inhaled or come in contact with body. Vapors can cause severe nausea, fainting or poisoning.
- Do not operate or spray near children. Keep children away from equipment at all times.
- Do not overreach or stand on an unstable support. Keep effective footing and balance at all times.
- Stay alert and watch what you are doing.
- Do not operate the unit when fatigued or under the influence of drugs or alcohol.
- Never aim spray gun at any part of the body.
- Follow all appropriate local, state, and national codes governing ventilation, fire prevention, and operation.
- The United States Government Safety Standards have been adopted under the Occupational Safety and Health Act (OSHA). These standards, particularly part 1910 of the General Standards and part 1926 of the Construction Standards should be consulted.
- Use only manufacturer authorized parts. User assumes all risks and liabilities when using parts that do not meet the minimum specifications and safety devices of the turbine manufacturer.
- Do not spray outdoors on windy days.
- Use only Earlex hose.

CONTROLS AND FUNCTIONS

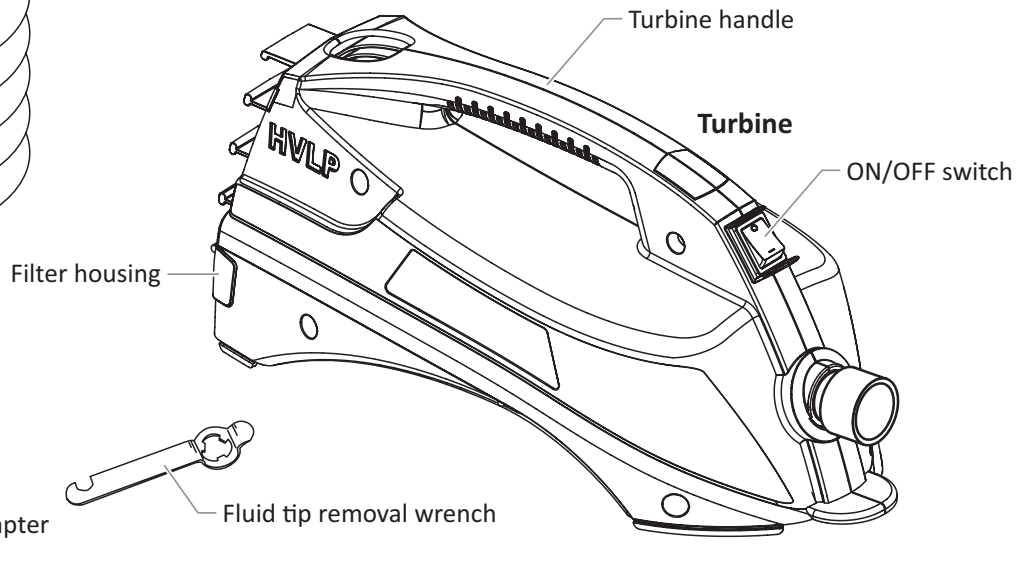
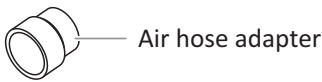
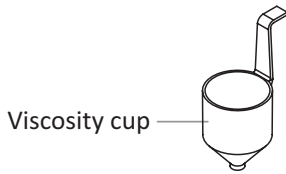
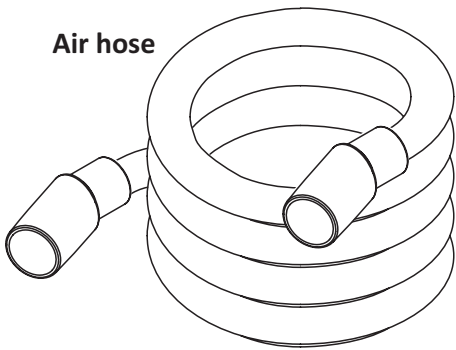
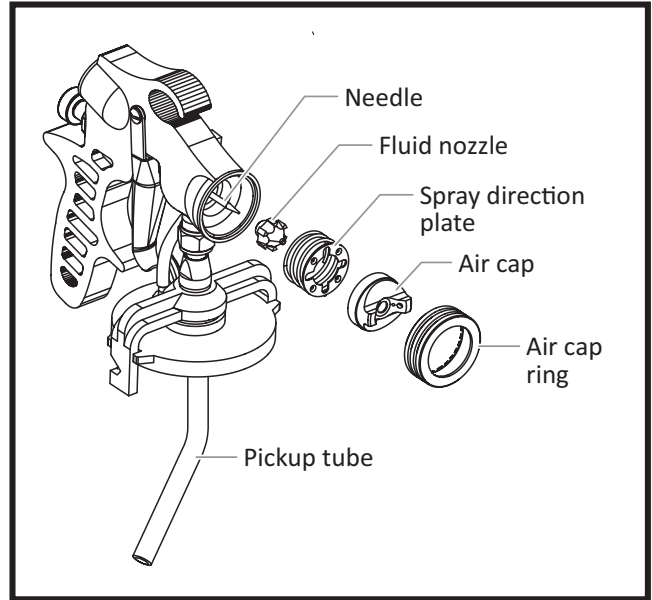
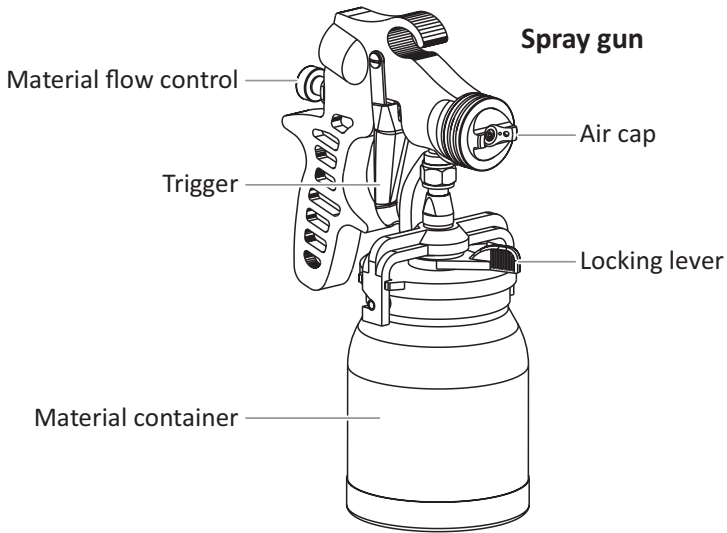

FLUID TIPS AND NEEDLES

Paints, varnishes, wood finishes, etc, are manufactured using a variety of materials and have widely different viscosities. You may find that the 1.5mm fluid tip and needle supplied with this spray gun does not enable you to spray your particular choice of finish exactly as you would like.

In such cases a change of fluid tip and needle size will probably solve this problem. In general, thicker, more viscose materials are best sprayed through a larger fluid tip to give best coverage. Thinner, less viscose materials are best sprayed through a smaller fluid tip. To allow for these variations fluid tip and needle sets are available as optional extras in 1.0mm, 2.0mm and 2.5mm (See page 13).

See page 12 for instructions on how to change the needle and nozzle set.

CONTROLS AND FUNCTIONS

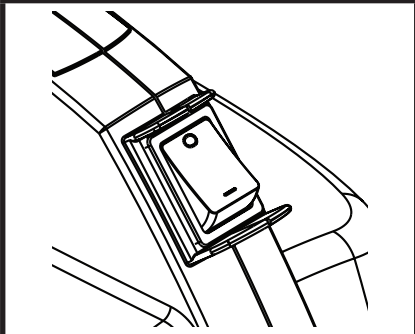

ON/OFF SWITCH

The ON/OFF switch turns power to the turbine on and off. The ON/OFF switch is located on top of the carrying handle of the turbine.

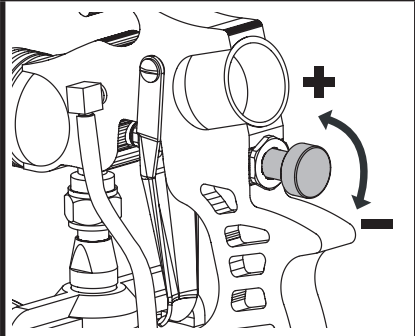

MATERIAL FLOW CONTROL

The material flow control determines the amount of spray material that is sprayed from the spray nozzle.

Set the material flow by turning the knob on the rear of the spray gun.

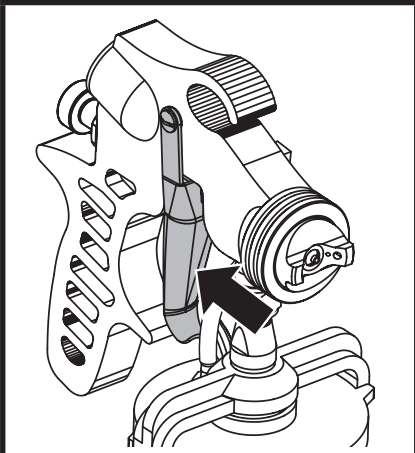

TRIGGER

Pulling the trigger will deliver spray material from the material container to the nozzle assembly, where it is sprayed.

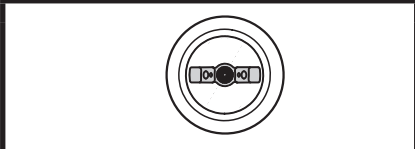

AIR CAP

Adjust the spray pattern by turning the air cap ears. Adjust the air cap to your intended movement direction of the spray gun.

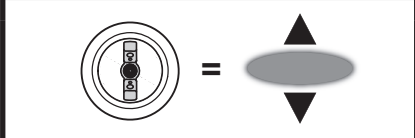

Horizontal pattern (use 'up and down' spraying motion)

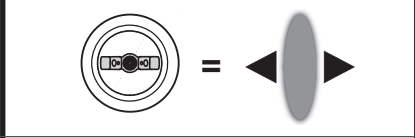

Vertical pattern (use 'side to side' spraying motion)

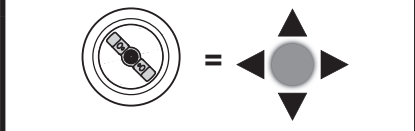

Round pattern (use 'side to side' or 'up and down' spraying motion)

MATERIAL PREPARATION

SELECTING PAINT

Your Wagner Earlex 5700 can be used with a wide variety of paints, stains and coatings such as latex, deck and fence stain, sealers, varnishes, wood preservatives, enamels, oil and water-based paints and automotive paints. However, some materials cannot be sprayed so please check the recommendation of the manufacturer before buying the paint. If a material refers to brush application only then it usually cannot be sprayed.

THIS UNIT CANNOT BE USED FOR TEXTURED PAINTS. USE OF THESE MATERIALS WILL CAUSE PREMATURE WEAR, WHICH WILL VOID YOUR WARRANTY. TO OBTAIN THE BEST RESULTS FROM YOUR SPRAY STATION, PLEASE READ THE INSTRUCTIONS CAREFULLY BEFORE USE.

SURFACE AND JOB PREPARATION

Preparation of the surface and thinning of the paint are the two most important areas to be concerned with to obtain the best results from your spray kit. Ensure all surfaces are free from dust, dirt, rust and grease. If necessary rub down with sandpaper, or similar. Masking of areas is important to ensure you do not spray those areas you wish to remain untouched.

THINNING

Your Wagner Earlex 5700 is supplied with a viscosity cup. Viscosity is a technical term used to indicate if a product is very thin or very thick. If thin, the viscosity is said to be low, while if very thick the viscosity is said to be high. Viscosity is measured in seconds. In order to spray some materials they need to be “thinned” (diluted). Thinning is very important when spraying. Most paints, etc are supplied ready for brush application and may need to be thinned (diluted) for spraying purposes.

The Wagner Earlex 5700 has a viscosity rating of 160 seconds. If the paint has emptied the viscosity cup in less than 160 seconds then you will not need to thin your paint or material. If it is above this then thinning will be required.

Your Wagner Earlex 5700 comes equipped with a Viscosity Cup (A), which will help you determine the thickness of the paint. To test a liquids viscosity, dip the viscosity cup into the material and fill up to the top, lift free and time how long it takes for the paint to empty the viscosity cup. Stop when the continuous flow ends from the bottom of the cup. The time determines the material viscosity and the need for the paint to be thinned before being sprayed (Fig.1).

If the paint requires thinning, start with a 10% dilution of the paint. To do this, fill a quart container with the required paint. The viscosity cup supplied with the unit holds 1/10 of a quart. Block the hole in the viscosity cup and fill up with the required thinners. Add the thinners to the paint and stir well.

If the paint requires further thinning, dilute the paint by another 5% (5% will be equal to half a viscosity cup) with the required thinners and measure the viscosity. If the paint is not at its recommended viscosity, repeat the above step.

Follow the manufacturer’s guide for thinning in conjunction with a spray gun. If in doubt please contact the manufacturer of the paint. The viscosity cup will help you determine the correct thickness of the paint. Paint is “thinned” by adding the substance which the paint is based upon. If a water-based paint then water is added, if oil-based then mineral spirit.

As some paints, wood preservatives and other sprayable materials contain particles that have differing qualities, please ensure that, when filling the paint container of the spray gun, the paint is filtered through either a funnel with a filter on it or through nylon tights or stockings. This will ensure that no large particles enter the paint container, so preventing blockages and providing you with trouble-free spraying. Ensure that suitable ear protection, face mask, gloves and goggles are worn at all times when spraying.

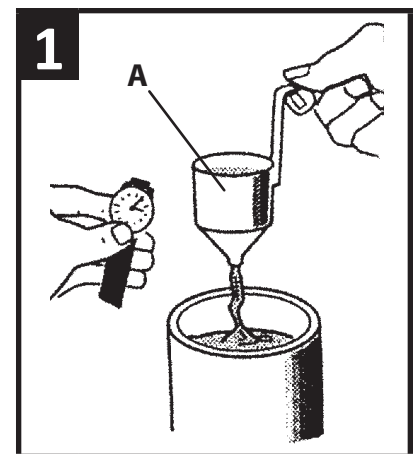

ASSEMBLY



NEVER point the spray gun at any part of the body.



Make sure the power cord is unplugged during assembly.

Attention

1. Fill the container with the material to be sprayed.
2. Align the pickup tube: Loosen the nut above the container that allows the lid to spin the pickup tube into position. Tighten the nut when the pickup tube is in the desired position.
 - A If spraying downward, the angled end of the pickup tube should be pointing toward the front of the container.
 - B If spraying upward, the angled end of the pickup tube should be pointing toward the rear of the container.
3. Make sure the clamp lever is turned fully to the right.
4. Rotate the paint container until the 2 pins locate into the recesses in the yoke. Tighten the clamp lever to secure the container to the lid. Do not over-tighten.
5. Attach the adapter to the opening on the back of the spray gun. Attach the air hose to the opening on the back of the adapter. Make sure both connections are tight.
6. Insert the air hose tightly into the connection into the turbine.

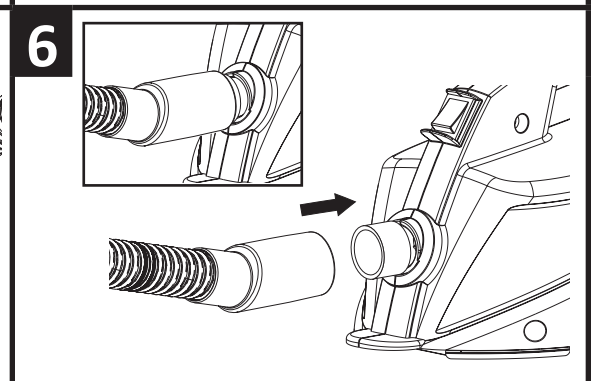
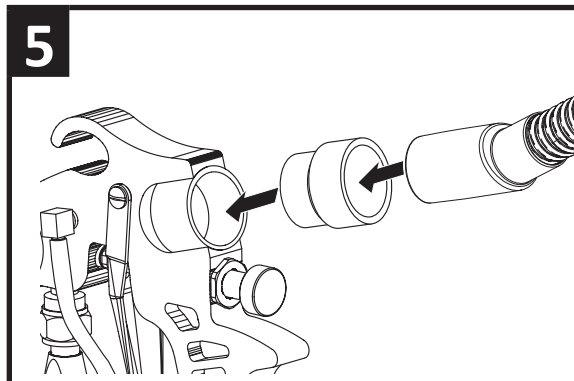
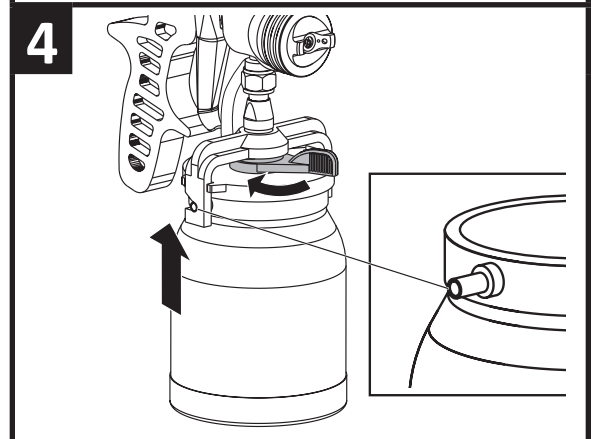
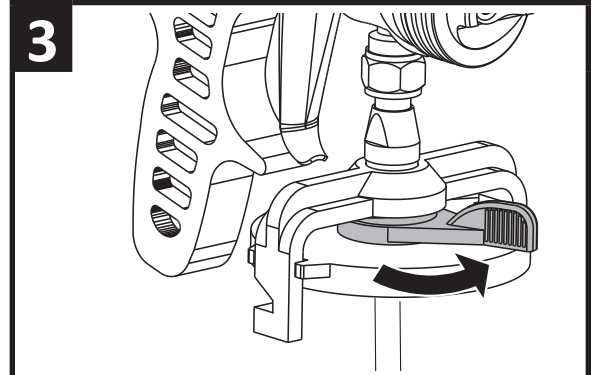
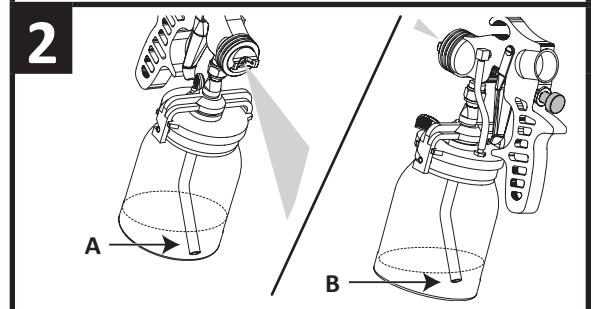
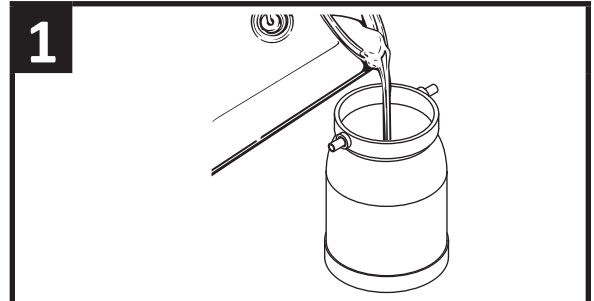

SPRAYER CONTROLS



Spray performance will depend upon a number of factors: material thickness, spray pattern selected, and material flow. Testing different control settings will help you achieve the desired results. See descriptions below to help with your project.

MATERIAL FLOW CONTROL

The material flow control determines the amount of material that is sprayed from the spray gun.

Set the material flow by turning the knob on the rear of the spray gun.

- For thicker materials, it is recommended that you start with the highest material flow setting and then gradually **decrease** the flow to suit your particular spraying needs.
- For thinner materials, it is recommended that you start with a low material flow setting, and then gradually **increase** the flow to suit your particular spraying needs.
- The higher the flow setting, the quicker you will have to work in order to avoid drips and sags in your spray pattern.

Tip: Spraying with the control set too high will result in a spray pattern that runs and sags (too much material).

Tip: Spraying with the control set too low will result in a spray pattern that does not cover (not enough material). Also, if the knob is loosened too much, it can fall out. Replace by threading it back in.

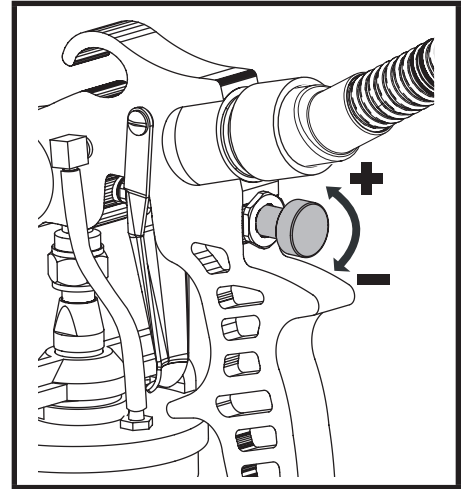

ADJUST SPRAY PATTERN

Adjust the spray pattern by turning the air cap ears.

The positions of the air cap and the corresponding spray pattern shapes are illustrated below.

Test each pattern and use whichever pattern is suitable for your application.

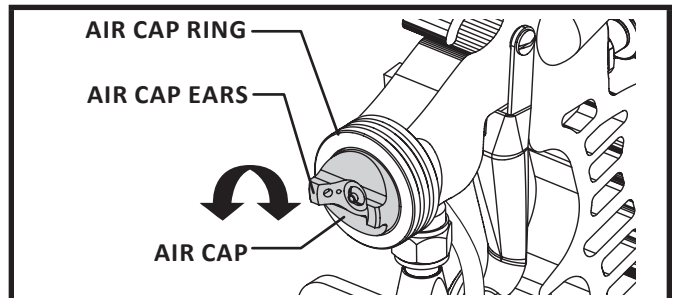

NEVER trigger the gun while turning the air cap. **NEVER** point the spray gun at any part of the body.



Attention

When changing the spray pattern, make sure the air cap ring is not loosened.

Horizontal pattern 	→ Use 'up and down' spraying motion
Vertical pattern 	→ Use 'side to side' spraying motion
Round pattern 	→ Use 'up and down' or 'side to side' spraying motion → Use lower material flow → For coating smaller areas, corners and edges

PROPER SPRAYING TECHNIQUE



The room you are spraying must be properly masked off in order to prevent overspray from covering anything you do not want sprayed. Make sure you have properly masked the room.



If spraying with a paint sprayer is new or unfamiliar to you, it is advisable to practice on a piece of scrap wood or cardboard before beginning on your intended workpiece and/or test with water.

SURFACE PREPARATION

All objects to be sprayed should be thoroughly cleaned before spraying material on them. Areas not to be sprayed may, in certain cases, need to be masked or covered.

SPRAY AREA PREPARATION

The spray area must be clean and free of dust in order to avoid blowing dust onto your freshly sprayed surface.

HOW TO SPRAY PROPERLY



It is important to keep your arm moving whenever the gun is being triggered. If you pause or linger in one spot too long, too much material will be sprayed to the surface.

- Position the spray gun perpendicular to and six (6) to eight (8) inches from the spray surface, depending upon the spray pattern size desired. With reduced material flow, you can get closer on the spraying surface.
- Spray parallel to the surface with smooth passes at a consistent speed as illustrated (A). Doing this will help avoid irregularities in the finish (i. e. runs and sags).
- Always apply a thin wet coat of material on the first pass and allow to dry before applying a second, slightly heavier coat.
- When spraying, overlap each spray pass by at least 50%. This will ensure full coverage.
- When spraying, trigger the gun **before** the spray object and release the trigger **after** you are past the spray object.



During a project, periodically wipe the nozzle tip with a cloth to remove any dried paint.

When you quit spraying for any length of time, turn the turbine OFF and place the spray gun into the spray gun holder on the turbine.

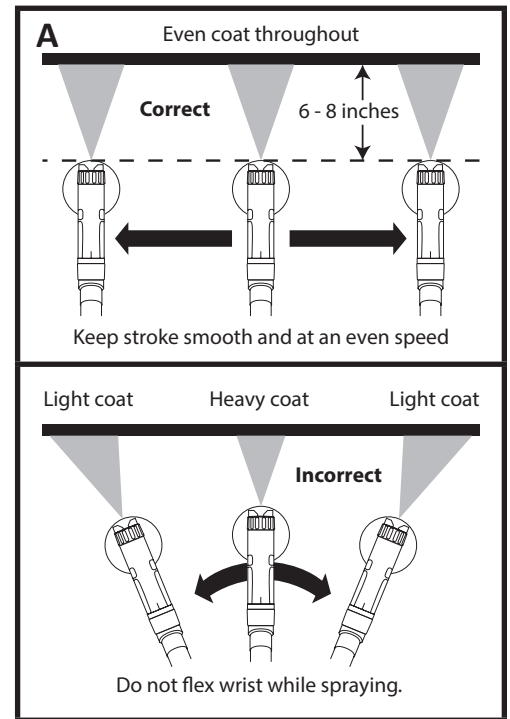

CLEANUP



When cleaning, use the appropriate cleaning solution (warm, soapy water for latex materials; mineral spirits for oil-based materials).

FLUSHING THE SPRAY GUN / CONTAINER



Attention

Never clean air cap or air holes in the nozzle with sharp metal objects. Do not use solvents or lubricants containing silicone.



Special cleanup instructions for use with flammable solvents (must have a flashpoint above 100°F (38°C):

- Always flush spray gun outside.
- Area must be free of flammable vapors.
- Cleaning area must be well-ventilated.
- Do not submerge turbine!

1. Turn turbine OFF.
2. Remove the container and empty any remaining material.
3. Thoroughly rinse the material container with warm, soapy water (or mineral spirits for oil-based materials).
4. Fill the material container halfway with cleaning solution and spray cleaning solution through the gun into a waste container.



Attention

If you cleaned the sprayer using mineral spirits, repeat steps 1-4 using warm, soapy water.

Move on to “Cleanup - Cleaning the Spray Gun”, page 11 for more thorough cleaning.

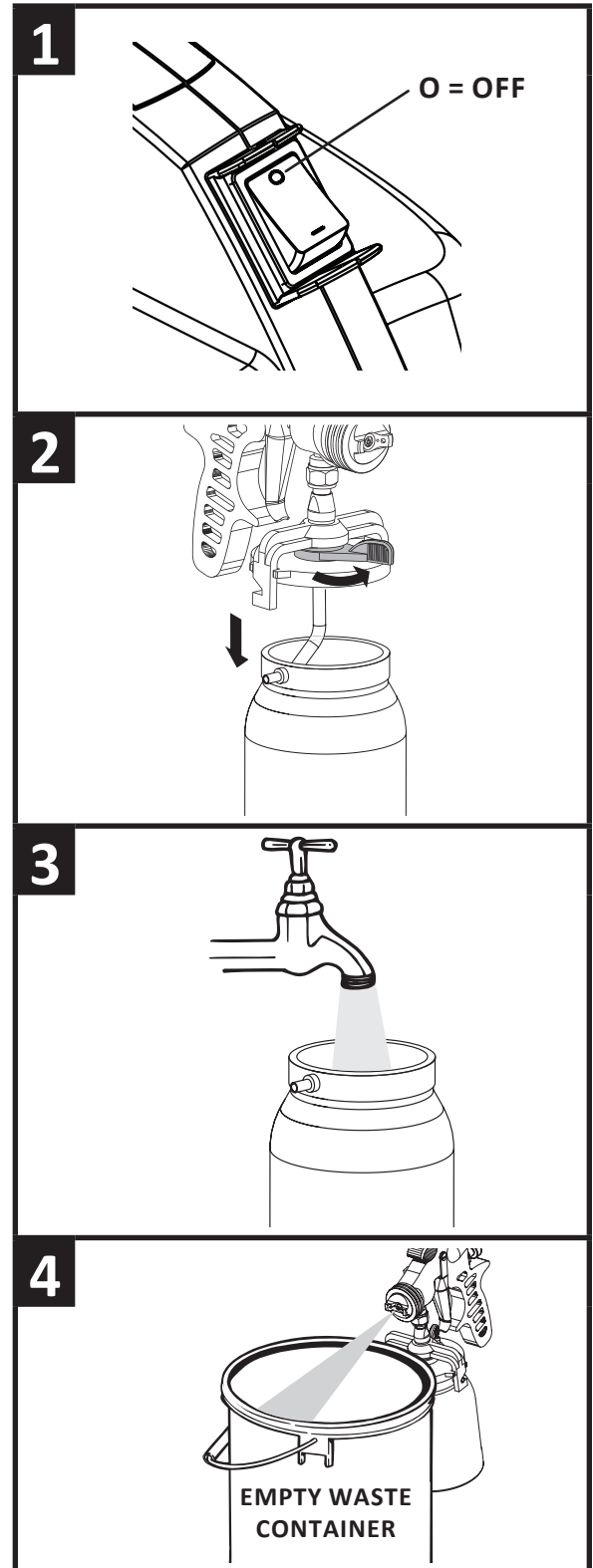

CLEANUP

CLEANING THE SPRAY GUN

1. Turn the turbine off and make sure power cord is unplugged. Remove the air hose from the rear of the spray gun.
2. Unscrew the air cap ring (1) and remove the air cap (2) and spray directional plate (3).
3. Using the fluid nozzle wrench, remove the fluid nozzle (4). Clean all parts with a cleaning brush and the appropriate cleaning solution.
4. Using a cleaning brush, brush inside the nozzle housing (5). Make sure to wipe down the underside of the container lid (6). Make sure the seal underneath is free from spray materials.
5. Carefully unscrew the material volume control knob (7). Remove the spring (8). Pull back on the trigger and remove the needle (9). Clean all parts with a cleaning brush and the appropriate cleaning solution.
6. Reassemble all parts. Start by replacing the fluid nozzle (4) into the spray gun and tighten with the wrench.
7. Slide the needle (9) back into the rear of the spray gun and make sure the tip sits inside the fluid nozzle opening at the front of the gun. Replace the spring (8) and material volume control knob (7) and tighten the knob by hand.

Replace the directional plate (3), the air cap (2) and the air cap ring (1).

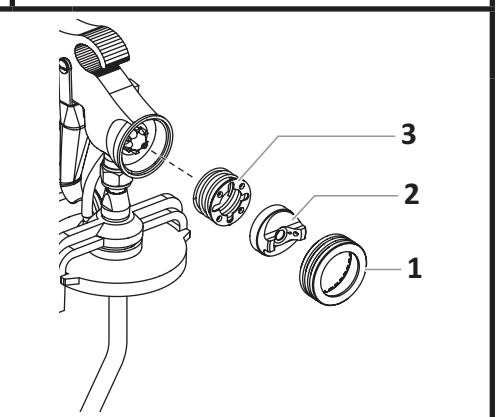
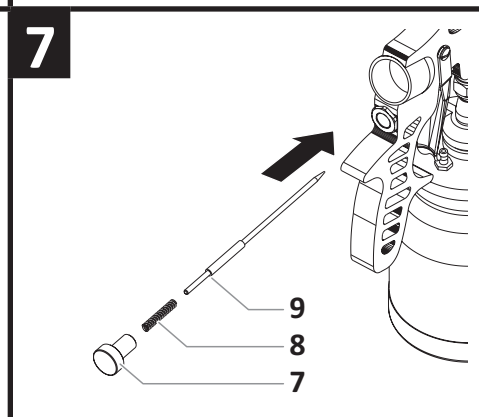
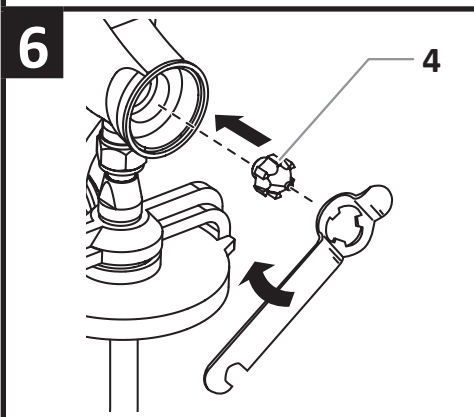
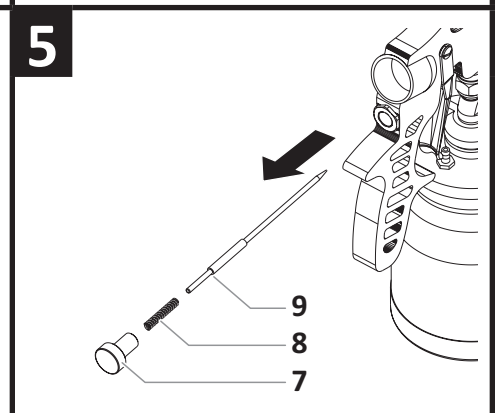
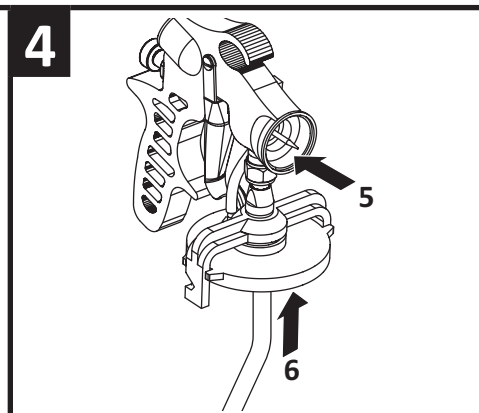
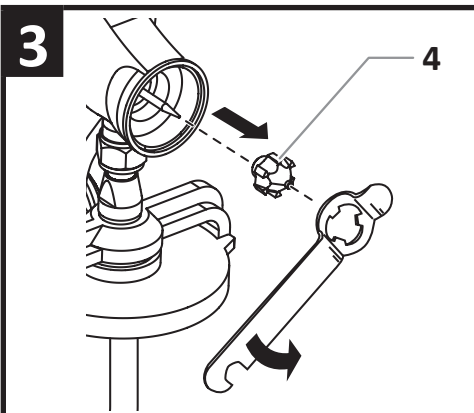
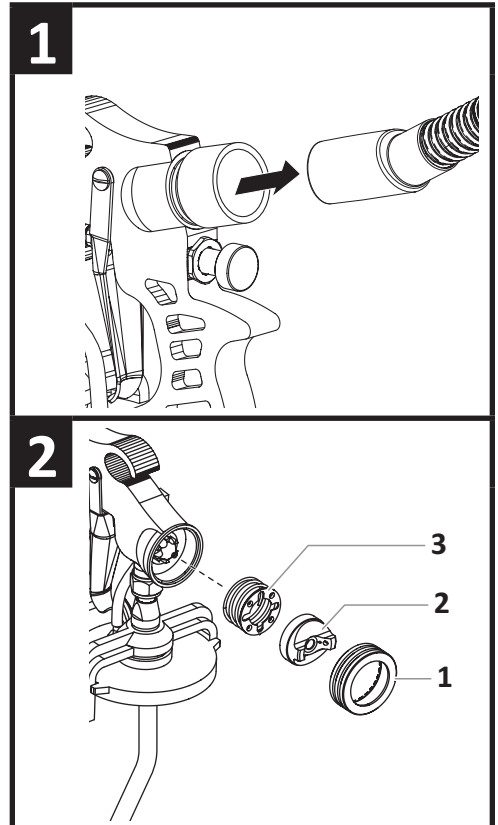

MAINTENANCE

REPLACING THE FILTER



Attention

Before every use, you should inspect the air filters in the turbine to see if it is excessively dirty. If it is dirty, follow these steps to replace it.

Never operate your unit without the air filters. Dirt could be sucked in and interfere with the function of the unit.

1. Lift up on the tabs on the filter housing and remove.
2. Remove the dirty filter from the turbine and replace with a new one. The smooth side of the air filter must be placed toward the turbine.

Secure the cover back onto the turbine.

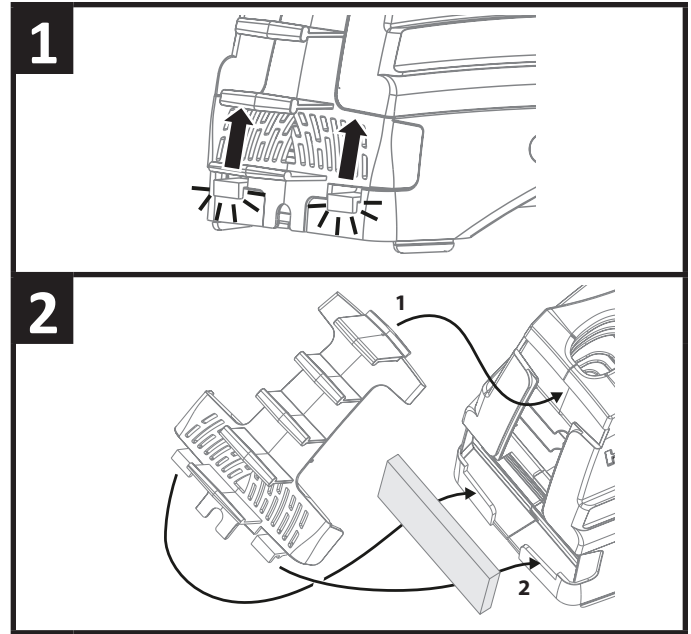

CHANGING THE SPRAY NEEDLE



Refer to the Parts List for ordering information.

Make sure the turbine is unplugged and the air hose has been removed from the spray gun.

1. Unscrew the air cap ring (1) and remove the air cap (2), and spray directional plate (3).
2. Using the fluid nozzle wrench, remove the fluid nozzle (4).
3. Carefully unscrew the material volume control knob (7). Remove the spring (8). Pull back on the trigger and remove the needle (9).

Reassemble with the new parts. Start by replacing the new fluid nozzle (4) into the spray gun and tighten with the wrench.

Slide the new needle (9) back into the rear of the spray gun and make sure the tip sits inside the fluid nozzle opening at the front of the gun. Replace the spring (8) and material volume control knob (7) and tighten the knob by hand.

Replace the directional plate (3), the air cap (2) and the air cap ring (1).

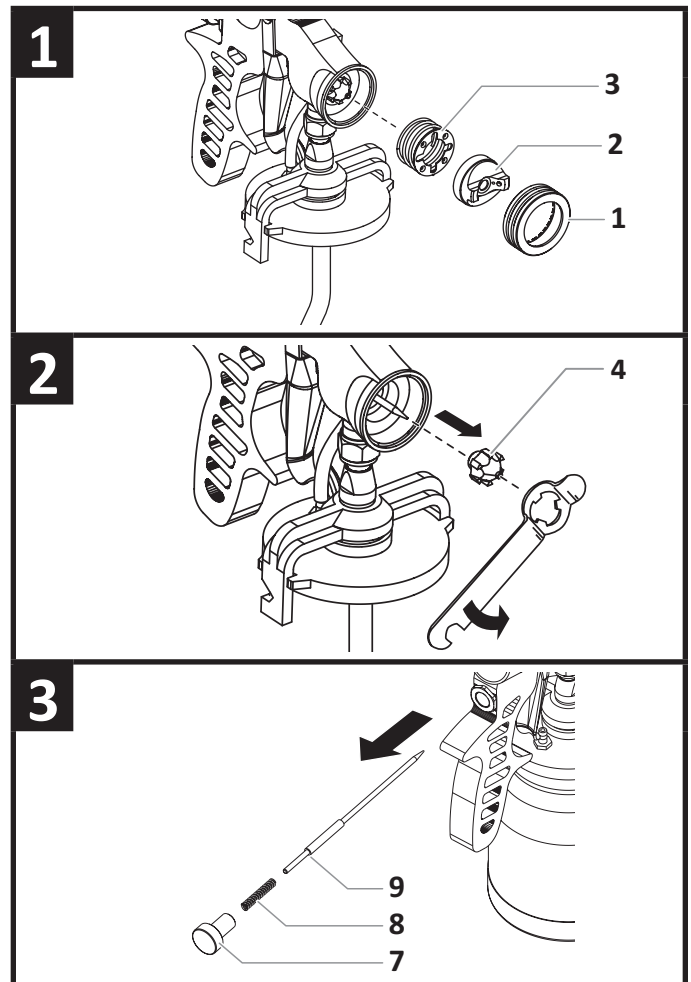

TROUBLESHOOTING

PROBLEM	CAUSE	SOLUTION
Problem A: Little or no material flow	<ol style="list-style-type: none"> 1. Nozzle clogged. 2. Suction tube clogged. 3. Material flow setting too low. 4. No pressure build up in container. 5. Air filter clogged. 6. Spray material too thick. 	<ol style="list-style-type: none"> 1. Clean. 2. Clean. 3. Increase material flow setting. 4. Tighten container or container lid and check the clear tube. 5. Change 6. Thin.
Problem B: Material leaking	<ol style="list-style-type: none"> 1. Nozzle loose. 2. Nozzle worn. 3. Material build-up on air cap and nozzle. 	<ol style="list-style-type: none"> 1. Tighten. 2. Replace. 3. Clean.
Problem C: Spray pattern too thick, runs and sags	<ol style="list-style-type: none"> 1. Material flow setting too high. 2. Applying too much material. 	<ol style="list-style-type: none"> 1. Decrease material flow setting. 2. Adjust material flow or increase movement of spray gun.
Problem D: Spray nozzle spits	<ol style="list-style-type: none"> 1. Material in container running out. 2. Air filter clogged. 	<ol style="list-style-type: none"> 1. Refill. 2. Change.
Problem E: Too much overspray	<ol style="list-style-type: none"> 1. Gun too far from spray object. 2. Material flow setting too high. 	<ol style="list-style-type: none"> 1. Reduce distance (6"-8" is ideal). 2. Decrease the material flow.
Problem F: Pattern is very light and plotchy	<ol style="list-style-type: none"> 1. Moving the spray gun too fast. 2. Material flow setting too low. 	<ol style="list-style-type: none"> 1. Adjust material flow or decrease movement of spray gun. 2. Increase material flow setting.

OPTIONAL EXTRAS

Needles and fluid tips of different sizes can be obtained as sets under the following accessory numbers. Please call our toll free helpline to order these at 888-783-2612.

Part No.	Description
OHV5ACC10US	1.0mm dia fluid tip, needle & seal
OHV5ACC15USR	1.5mm dia fluid tip, needle & seal
OHV5ACC20USR	2.0mm dia fluid tip, needle & seal
OHV5ACC25USR	2.5mm dia fluid tip, needle & seal
OL0190A	Material container, solvent based materials*

*The PTFE coating inside the material container included with the sprayer is meant for water-based materials. For solvent based materials, especially lacquers, order cup part number OL0190A for a non-coated material container.



This unit contains no servicable electrical parts. Do not attempt to service yourself. Store indoors with the cord wrapped around the turbine handle.



Have you tried the recommendations above and are still having problems? In the United States, to speak to a customer service representative, call our Technical Service at 1-888-783-2612.

PARTS LIST • LISTE DE PIÈCES • LISTA DE PIEZAS

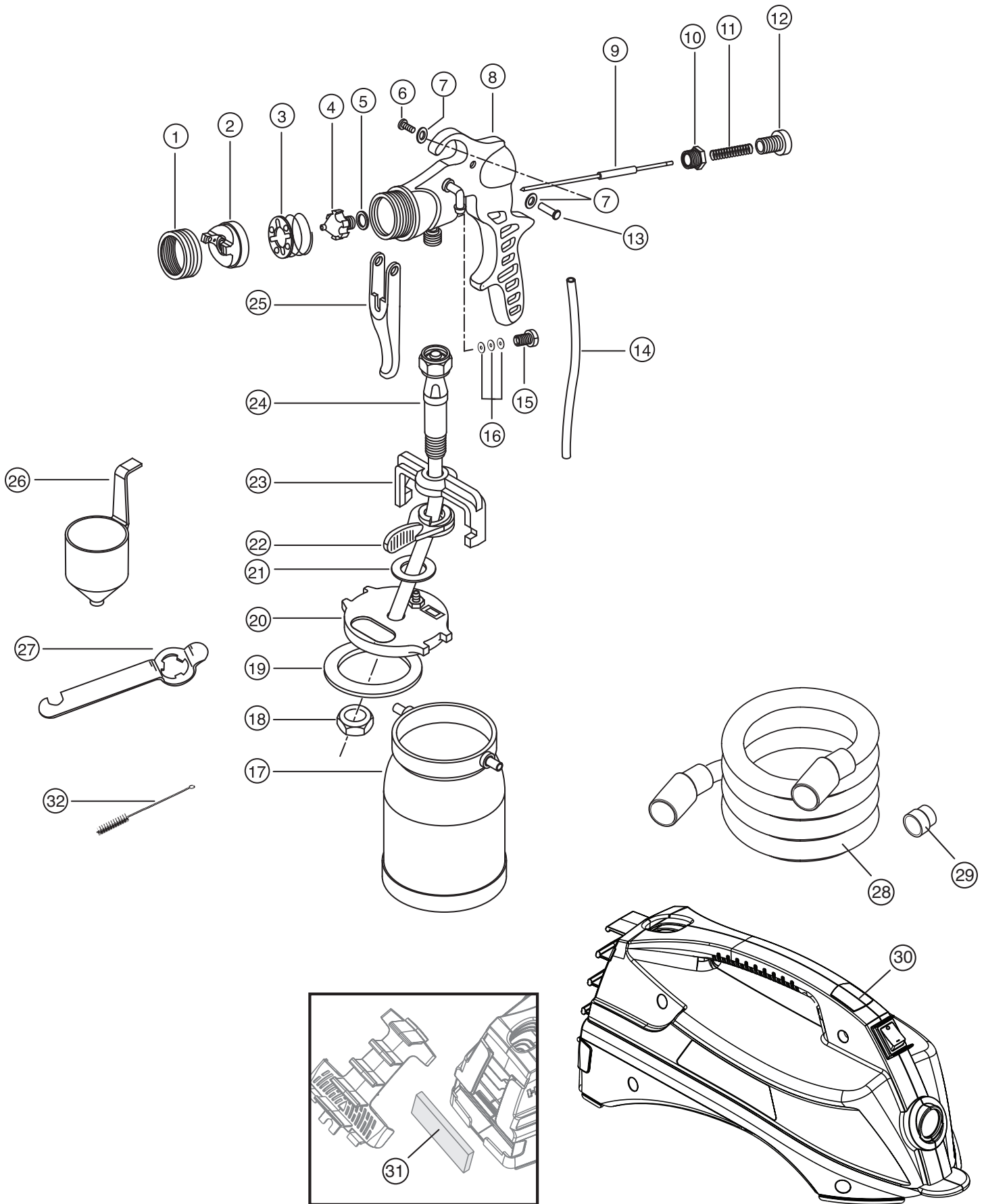

PARTS LIST • LISTE DE PIÈCES • LISTA DE PIEZAS

#	Part No. N° de pièce Pieza No.	English Description	Français Description	Español Descripción
1	L0151	Air Cap Ring	Anneau du chapeau d'air	Anillo del soporte de la boquilla
2	2354029	Air Cap	Chapeau d'air	Soporte de la boquilla de aire
3	L0162	Air Distributor Plate	Assemblage disque d'orientation du jet	Placa del distribuidor de aire
4*	-----	Fluid Tip, 1.5 mm	Buse 1,5mm	Boquilla de 1.5mm
5*	2354077	Fluid Tip Seal	Joint buse	Sello de la boquilla
6	L0179	Pivot Screw	Vis axe	Tornillo pivote
7	L0195	Washer	Rondelle	Arandela
8	-----	Main Body	Assemblage partie principale	Ensamblaje del cuerpo principal
9*	-----	Fluid Needle 1.5 mm	Pointeau 1,50mm	Aguja del fluido de 1.5mm
10	-----	Adaptor	Adaptateur	Adaptador
11	2353978	Spring	Ressort	Muelle
12	L0176	Fluid Adjusting Screw	Vis de réglage	Tornillo de ajuste
13	L0178	Pivot	Axe	Pivote
14	2353984	Air Feed Tube	Tube plongeur	Tubo de alimentación de aire
15	L0173	Gland Nut	Écrou de garniture	Tuerca del prensaestopas
16	2354010	Gland Washer (3 pcs)	Rondelle d'écrou de garniture (3 pièces)	Arandela del prensaestopas (3 piezas)
17	2353992	Paint Container (water based coatings)	Réservoir de peinture (matériaux à base d'eau)	Contenedor de pintura (materiales a base de agua)
18	L0189	Centre Bolt Nut	Écrou de boulon central	Tuerca de perno central
19	2353989	Gasket	Joint d'étanchéité	Junta
20	L0187	Lid	Assemblage couvercle	Ensamblaje de la tapa
21	L0186	Shim	Cale	Arandela de separación
22	L0185	Clamp Lever	Levier de serrage	Palanca de sujeción
23	L0184	Yoke	Fourche	Boca de enganche
24	2354161	Centre Bolt & Pick-Up Tube	Assemblage écrou central et tube plongeur	Conjunto tubo de recolección y perno central
25	L0177	Trigger	Gâchette	Palanca de control
26	153165	Viscosity Cup	Godet de viscosité	Depósito de viscosidad
27	L0191	Wrench	Clé	Llave de tornillos
28	2314523	Air hose	Tuyau d'air	Manguera de aire
29	V0710	Hose adapter	Adaptateur de tuyau d'air	Adaptador de manguera de aire
30	-----	Turbine (includes item 31)	Turbine (includ de pièce 31)	Turbina (incluye le articulo 31)
31	V0377	Filter	Filter	Filtro
32	514209	Cleaning brush	Brosse de nettoyage	Cepillo de limpieza
*	OHV5ACC15USR	1.5mm dia fluid tip, needle & seal	Buse, pointeau et joint Ø 1.5mm	Aguja, sello y boquilla de fluido, 1.5mm diám.

LIMITED WARRANTY • GARANTIE LIMITÉE • GARANTÍA LIMITADA

PAINT SPRAY EQUIPMENT

This product, manufactured by Wagner Spray Tech Corporation (Wagner), is warranted against defects in material and workmanship for two years following date of purchase if operated in accordance with Wagner's printed recommendations and instructions. This warranty does not cover damage resulting from improper use, accidents, user's negligence or normal wear. This warranty does not cover any defects or damages caused by service or repair performed by anyone other than a Wagner Authorized Service Center.

ANY IMPLIED WARRANTY OF MERCHANTABILITY OR FITNESS FOR A PARTICULAR PURPOSE IS LIMITED TO TWO YEARS FOLLOWING DATE OF PURCHASE. WAGNER SHALL NOT IN ANY EVENT BE LIABLE FOR ANY INCIDENTAL OR CONSEQUENTIAL DAMAGES OF ANY KIND, WHETHER FOR BREACH OF THIS WARRANTY OR ANY OTHER REASON. THIS WARRANTY DOES NOT APPLY TO ACCESSORIES.

THIS PRODUCT IS DESIGNED FOR HOME USAGE ONLY. IF USED FOR COMMERCIAL OR RENTAL PURPOSES, THIS WARRANTY APPLIES ONLY FOR 30 DAYS FROM DATE OF PURCHASE.

If any product is defective in material and workmanship during the applicable warranty period, return it with proof of purchase, transportation prepaid to Wagner Spray Tech, 6151 Queens Ave., Otsego, MN 55330. Wagner will either repair or replace the product (at Wagner's option) and return it to you, postage prepaid.

SOME STATES DO NOT ALLOW LIMITATIONS ON HOW LONG AN IMPLIED WARRANTY LASTS OR THE EXCLUSION OF INCIDENTAL OR CONSEQUENTIAL DAMAGES, SO THE ABOVE LIMITATION AND EXCLUSION MAY NOT APPLY TO YOU. THIS WARRANTY GIVES YOU SPECIFIC LEGAL RIGHTS, AND YOU MAY ALSO HAVE OTHER RIGHTS WHICH VARY FROM STATE TO STATE.

PULVÉRISATEUR DE PEINTURE

Cet article fabriqué par Wagner Spray Tech Corporation (Wagner) est garanti contre tout défaut de fabrication et de matériaux pour une période de deux ans suivant la date d'achat, à condition qu'il soit utilisé conformément aux recommandations et aux instructions écrites de Wagner. La garantie ne couvre pas les dommages résultant d'un mauvais emploi, d'un accident, d'une négligence de la part de l'utilisateur ou de l'usure normale de l'article. Elle ne couvre pas non plus les défauts ou les dommages découlant de services d'entretien ou de réparations assurées par tout autre établissement qu'un centre de service après-vente agréé de Wagner.

TOUTE GARANTIE TACITE RELATIVE AUX QUALITÉS MARCHANDES OU À L'UTILISATION DE CE PRODUIT DANS UN BUT PARTICULIER N'EST VALABLE QUE POUR UNE PÉRIODE DE DEUX ANS À COMPTER DE LA DATE D'ACHAT. WAGNER NE SAURAIT ÊTRE TENU RESPONSABLE DES DOMMAGES FORTUITS OU INDIRECTS QUELS QU'ILS SOIENT, QUE CE SOIT POUR INOBSERVATION DE LA PRÉSENTE GARANTIE OU POUR TOUTE AUTRE RAISON. LA GARANTIE NE COUVRE PAS LES ACCESSOIRES.

CET ARTICLE A ÉTÉ CONÇU EXCLUSIVEMENT EN VUE D'UN USAGE DOMESTIQUE. LA GARANTIE NE SERA VALABLE QUE POUR 30 JOURS À COMPTER DE LA DATE D'ACHAT DE L'ARTICLE EST UTILISÉ À DES FINS COMMERCIALES OU DE LOCATION.

Si un produit démontre un défaut de matières ou de fabrication durant la période de garantie pertinente, le retourner avec la preuve d'achat, port payé, à Wagner Spray Tech, 6151 Queens Ave., Otsego, MN 55330. Wagner effectuera soit la réparation ou le remplacement du produit (au choix de Wagner) et vous le retournera, frais de poste payés.

COMME LES LIMITES DE TEMPS RELATIVES À UNE GARANTIE TACITE OU À L'EXCLUSION DES DOMMAGES DE NATURE FORTUITE OU INDIRECTE N'ONT PAS NÉCESSAIREMENT COURS DANS TOUTES LES PROVINCES, IL SE PEUT QUE LESDITES LIMITES OU EXCLUSIONS NE VOUS CONCERNENT PAS. CERTAINS DROITS PARTICULIERS VOUS SONT DÉVOLUS EN VERTU DE LA PRÉSENTE GARANTIE ET PEUVENT S'ACCOMPAGNER D'AUTRES DROITS EN FONCTION DE LA PROVINCE OÙ VOUS RÉSIDEZ.

EQUIPO DE ATOMIZACIÓN DE PINTURA

Este producto, fabricado por la Wagner Spray Tech Corporation (Wagner), está garantizado contra defectos de materiales y de mano de obra por dos años a partir de la fecha de compra siempre y cuando se utilice de acuerdo con las recomendaciones e instrucciones impresas de Wagner. Esta garantía no cubre daños ocasionados por el uso incorrecto, accidentes, negligencia por parte del usuario o el desgaste normal. Esta garantía no cubre cualquier defecto o daño ocasionado por el servicio o las reparaciones llevadas a cabo fuera de un Centro de Servicio Wagner Autorizado.

CUALQUIER GARANTÍA IMPLÍCITA REFERENTE AL POTENCIAL COMERCIAL O ADAPTABILIDAD PARA UN USO PARTICULAR SE LIMITA A DOS AÑO A PARTIR DE LA FECHA DE COMPRA. WAGNER EN NINGÚN CASO SERÁ RESPONSABLE DE CUALQUIER DAÑO DIRECTO O INDIRECTO DE CUALQUIER TIPO, YA SEA POR VIOLACIÓN DE ESTA GARANTÍA O CUALQUIER OTRA RAZÓN. ESTA GARANTÍA NO SE APLICA A LOS ACCESORIOS.

ESTE PRODUCTO ESTÁ DISEÑADO PARA SER UTILIZADO EN EL HOGAR ÚNICAMENTE. SI SE UTILIZA PARA PROPÓSITOS COMERCIALES O DE ALQUILER, ESTÁ GARANTÍA ES VÁLIDA ÚNICAMENTE DURANTE 30 DÍAS A PARTIR DE LA FECHA DE COMPRA.

Si cualquier producto presenta defectos de materiales o de mano de obra durante el período de garantía, devuélvalo junto con la factura de compra y transporte prepago a Wagner Spray Tech, 6151 Queens Ave., Otsego, MN 55330. Wagner reparará o reemplazará el producto (a la opción de Wagner) y lo regresará a usted mediante flete prepago.

ALGUNOS ESTADOS, DEPARTAMENTOS O PROVINCIAS NO PERMITEN LIMITACIONES EN CUANTO AL PERÍODO DE VALIDEZ DE UNA GARANTÍA IMPLÍCITA NI LA EXCLUSIÓN DE DAÑOS DIRECTOS O INDIRECTOS. POR LA TANTO, LA LIMITACIÓN Y LA EXCLUSIÓN ANTERIOR PUEDEN NO APLICARSE A USTED. ESTA GARANTÍA LE OTORGA DERECHOS LEGALES ESPECÍFICOS Y USTED TAMBIÉN PUEDE TENER OTROS DERECHOS QUE VARÍAN DE UNA LOCALIDAD A OTRA.